



WEH[®] CONNECTORS

for breathing air filling and SCBA testing



© All rights reserved, WEH GmbH.

Unauthorized copies are strictly forbidden as well as the publishing and using without the written consent of the WEH company.

By the transfer of an up to date brochure or document all precursory versions will run out of validity. As a matter of principle the latest up to date version of brochures and other documents are valid. These versions can be found at www.weh.com

Our general terms and conditions and the agreement on protection of know-how and quality assurance (www.weh.com) are valid for consignments and all other services, unless otherwise agreed. We do not accept general terms and conditions of the purchaser.

WEH® is a registered trademark of the WEH GmbH.

» Table of contents

1 Breathing air products	4
1.1 Overview	4
2 CLICKMATE® TW154 Upgrading existing filling rigs	6
2.1 General	6
2.2 Ordering	8
3 CLICKMATE® TW154 Direct connection to hose filling systems	10
3.1 General	10
3.2 Ordering	12
4 CLICKMATE® Versions	14
4.1 Overview	14
5 WEH® Connector TW156 For respiratory protective equipment	16
5.1 General	16
5.2 Ordering	18
6 Further information	20
6.1 Technical appendix	20
6.2 Brochure data	23

» WEH® Connectors for breathing air

SETTING NEW STANDARDS FOR BA FILLING

Since 1980 WEH has offered an innovative range of quick connectors for pressure and function testing that achieves a connection in seconds. Included in the vast product range are WEH® Connectors for filling BA cylinders and for testing respiratory protective equipment.

Satisfied customers range from manufacturers of filling rigs and fire brigades.

CLICKMATE® FOR CONVERSION OF EXISTING FILLING RIGS AND UPGRADING HOSE FILLING SYSTEMS

Breathing air (BA) cylinders can now be filled quickly and easily using WEH® Conversion kits fitted to existing installations.

The **CLICKMATE®** TW154 grips directly into the thread of the cylinder valve thus eliminating strenuous hand tightening. A pressure assisted sealing piston provides a leak tight seal. The quick connection to the thread is achieved by moving an actuating loop through 90° which simultaneously engages the valve threads, sealing piston and a safety mechanism that prevents disconnection under pressure.



The WEH® Conversion kits are designed for upgrading existing filling rigs. Both 200 bar and 300 bar versions are available. The quick connectors are also available for upgrading hose filling systems.

FASTER TESTING OF RESPIRATORY PROTECTIVE EQUIPMENT WITH THE TW156 QUICK CONNECTOR

SCBAs used by fire brigades must be regularly function tested.

In order to speed up this test procedure, WEH has added the TW156 quick connector to its product range of BA products.

The lever actuated TW156 connects in seconds to the manual inlet valve of the respiratory protective device eliminating repetitive turning. By simply actuating the hand lever and placing the connector onto the inlet valve, then releasing the hand lever, the pressure medium can be applied.

To disconnect, simply actuate the hand lever and remove the TW156.

The TW156 quick connector is designed to suit BA sets with a max. operating pressure of 375 bar. It can either be mounted directly or connected by hose to the existing test unit. When used with a hose, the connector must be securely anchored when not in use.

TW156 is available with manual or pneumatic actuation.



» WEH® Connectors for breathing air

ILLUSTRATIONS



Existing BA cylinder filling rig after it has been upgraded to using the **CLICKMATE® TW154**



Testing of respiratory equipment with TW156 quick connector

» CLICKMATE® TW154 | Upgrading existing filling rigs

DESCRIPTION



Features

- Connection directly to the standard threads of the cylinder valves
- Quick connection in seconds without hand tightening
- Filling of breathing air cylinders becomes even easier and more efficient
- Improves operational safety and ergonomics

CLICKMATE® TW154 quick connector is designed for filling breathing air cylinders. Existing filling rigs equipped with screw connectors can be upgraded without problems.

The CLICKMATE® TW154 uses the split collet thread design that locks securely into standard threads of cylinder valves. Connection is made by lowering the operating loop through 90° which locks the split collet jaws into the cylinder valve and actuates the sealing piston. An integrated safety mechanism prevents disconnection under pressure.

CLICKMATE® TW154 is available, among others, for breathing air cylinders with a nominal operating pressure of 200 bar resp. 300 bar. For differentiation, the connector for 200 bar is equipped with a black locking lever and the connector for 300 bar with a red locking lever.

The quick connector is equipped with a NBR front seal and inner seals of FKM. Other sealing materials are available on request. It is the customer's responsibility to clarify the media compatibility.

All connectors are subjected to extensive pressure and durability tests.

Application

Quick connector for filling of BA cylinders in fire brigade BA filling installations for direct connection to existing filling rigs that have balancers to equalize weight and height.

TECHNICAL DATA

Characteristics	Basic version	Options
Max. allowable operating pressure PS	250 bar resp. 375 bar	On request
Temperature range	+5 °C up to +70 °C	On request
Medium	Breathing air (compressed air)	On request
Connection A (cylinder valve)	Standard connection for G5/8" female thread (DIN 477)	Other connections acc. to the corresponding national standard available. Special connections available.
Inlet B1	Depending on connection at the filling rig	On request
Material	Brass and corrosion-resistant stainless steel	On request
Sealing material	Front seal: NBR Inner seals: FKM	

» CLICKMATE® TW154 | Upgrading existing filling rigs

SYSTEM OVERVIEW

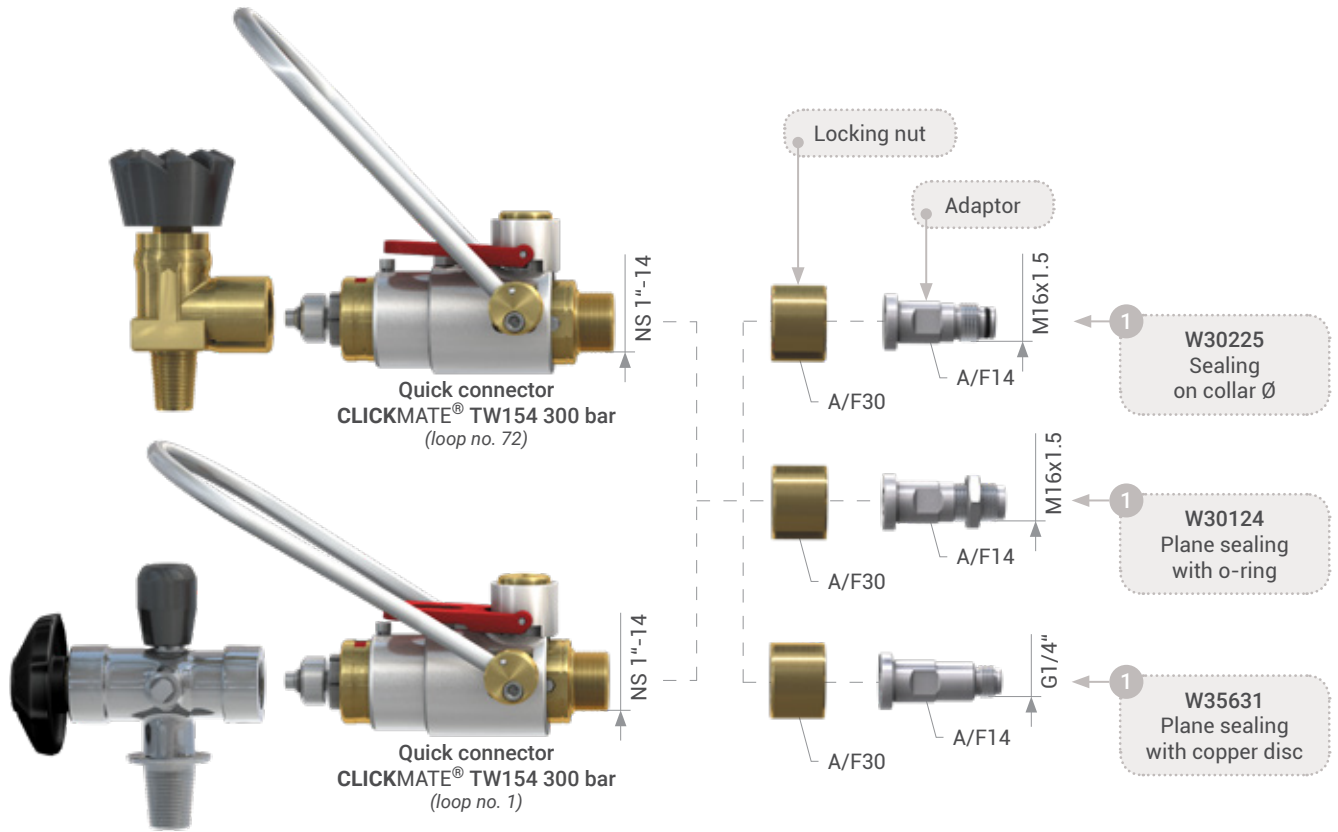

Filling rig with CLICKMATE® TW154 Connectors

» CLICKMATE® TW154 | Upgrading existing filling rigs

ORDERING | Quick connector CLICKMATE® TW154 with operating loop no. 72

approx. dimensions (mm)

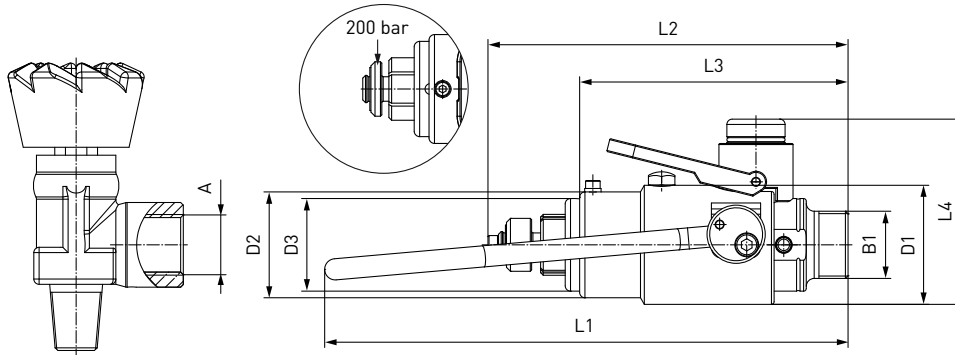

Part no.	Description	Pressure (PS)	A (female thread)	B1 (male thread)	L1	L2	L3	L4	D1	D2	D3
C1-92774-X01	CLICKMATE® TW154	250 bar	G5/8"*	NS 1"-14	198	126	102	70	45	40	35
C1-92775-X01	CLICKMATE® TW154	375 bar	G5/8"*	NS 1"-14	198	136	102	70	45	40	35

* acc. to DIN 477

ORDERING | Quick connector CLICKMATE® TW154 with operating loop no. 1 (suitable for Interspiro)

approx. dimensions (mm)

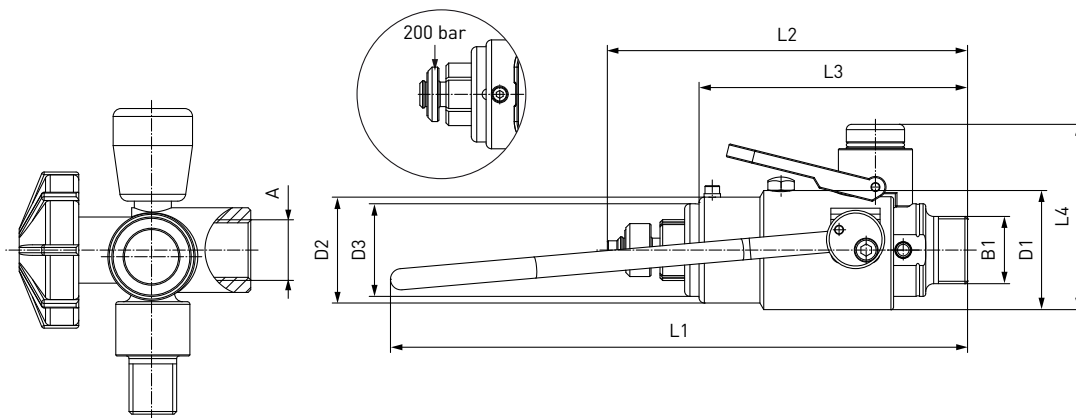

Part no.	Description	Pressure (PS)	A (female thread)	B1 (male thread)	L1	L2	L3	L4	D1	D2	D3
C1-109695-X01	CLICKMATE® TW154	250 bar	G5/8"*	NS 1"-14	198	126	102	70	45	40	35
C1-109696-X01	CLICKMATE® TW154	375 bar	G5/8"*	NS 1"-14	198	136	102	70	45	40	35

* acc. to DIN 477

» CLICKMATE® TW154 | Upgrading existing filling rigs

ACCESSORIES

The following accessories are available for the **CLICKMATE®** TW154:

1 Adaptors incl. locking nut

Adaptor for **CLICKMATE®** TW154 for connection to the filling rig.



Part no.	Description	Pressure (PS)	Connection
W30225	For connection to the filling rig	375 bar	M16x1.5 male thread o-ring sealing on collar Ø 12.9 mm
W30124	For connection to the filling rig	375 bar	M16x1.5 male thread o-ring plane sealing
W35631	For connection to the filling rig	375 bar	G1/4" male thread plane sealing

2 Weight and height balancing system TZ100

For safe positioning of the cylinders below the filling rig.

Note: Please note that a minimum space of 180 mm from connector centre to connector centre has to be observed at the filling rig!



Part no.	Description	Filling height
C1-66042	TZ100 System 1	825 - 870 mm
C1-66237	TZ100 System 2	840 - 910 mm
C1-66238	TZ100 System 3	880 - 980 mm
C1-66239	TZ100 System 4	955 - 1055 mm

SPARE PARTS

Various parts are available as spares for the **CLICKMATE®** TW154.

Part no.	Description
E51-308S508	Spare front seal for CLICKMATE® TW154

» CLICKMATE® TW154 | Direct connection to hose filling systems

DESCRIPTION



Features

- Connection directly to the standard threads of the cylinder valves
- Quick connection in seconds without hand tightening
- Filling of breathing air cylinders becomes even easier and more efficient
- Improves operational safety and ergonomics

CLICKMATE® TW154 quick connector is designed for filling respiratory air cylinders. Existing connectors for hose filling can be upgraded without problems.

The CLICKMATE® TW154 uses the split collet thread design that locks securely into standard threads of cylinder valves. Connection is made by lowering the operating loop through 90° which locks the split collet jaws into the cylinder valve and actuates the sealing piston. An integrated safety mechanism prevents disconnection under pressure.

CLICKMATE® TW154 is available, among others, for breathing air cylinders with a nominal operating pressure of 200 bar resp. 300 bar. For differentiation, the connector for 200 bar is equipped with a black locking lever and the connector for 300 bar with a red locking lever.

The quick connector is equipped with a NBR front seal and inner seals of FKM. Other sealing materials are available on request. It is the customer's responsibility to clarify the media compatibility.

All connectors are subjected to extensive pressure and durability tests.

Application

Quick connector for filling of BA cylinders in fire brigade BA filling installations for direct connection to hose filling systems.

TECHNICAL DATA

Characteristics	Basic version	Options
Max. allowable operating pressure PS	250 bar resp. 375 bar	On request
Temperature range	+5 °C up to +70 °C	On request
Medium	Breathing air (compressed air)	On request
Connection A (cylinder valve)	Standard connection for G5/8" female thread (DIN 477)	Other connections acc. to the corresponding national standard available. Special connections available.
Inlet B1	Depending on connection at the filling hose	On request
Material	Brass and corrosion-resistant stainless steel	On request
Sealing material	Front seal: NBR Inner seals: FKM	

» CLICKMATE® TW154 | Direct connection to hose filling systems

SYSTEM OVERVIEW

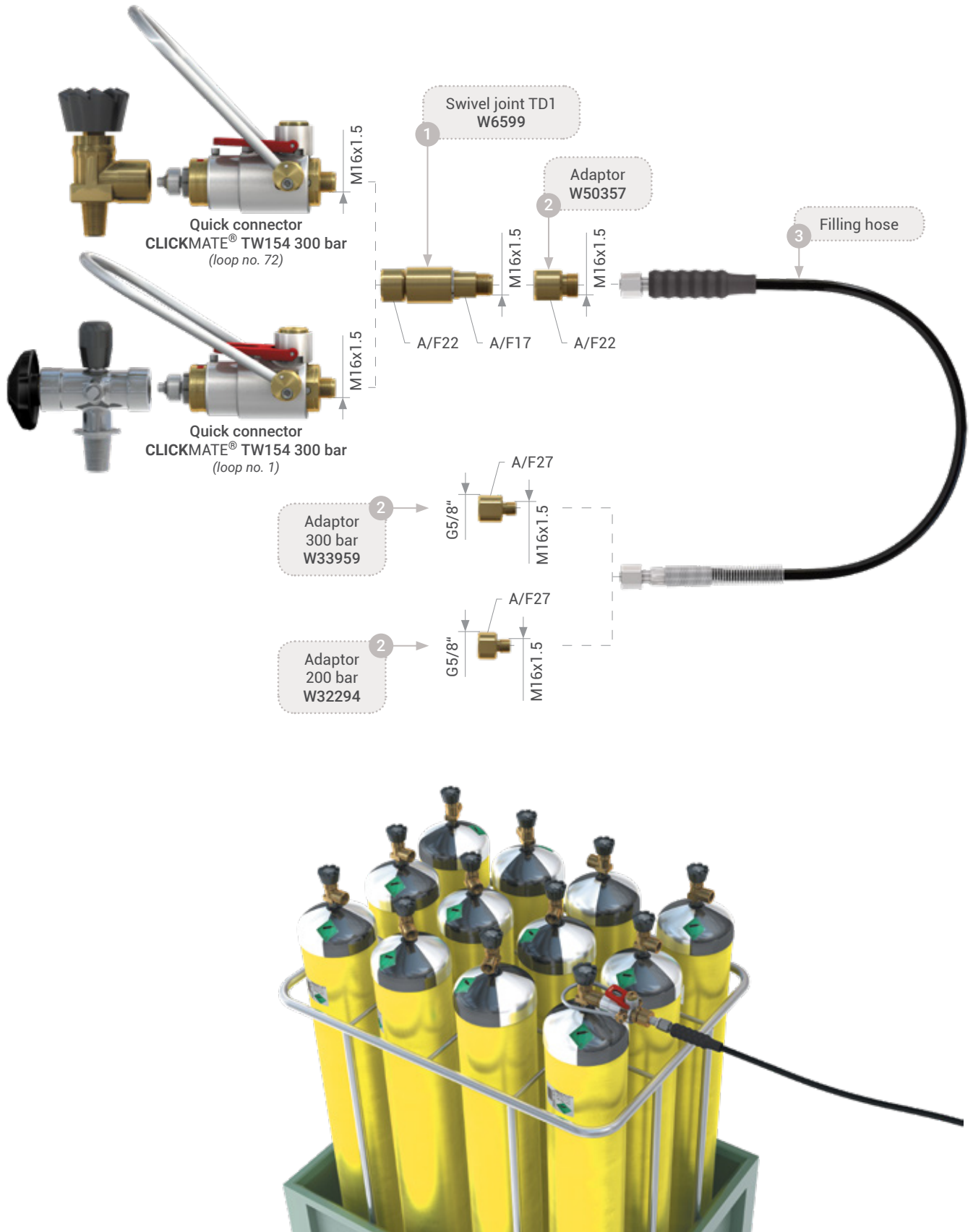

Hose filling system with CLICKMATE® TW154

» CLICKMATE® TW154 | Direct connection to hose filling systems

ORDERING | Quick connector CLICKMATE® TW154 with operating loop no. 72

approx. dimensions (mm)

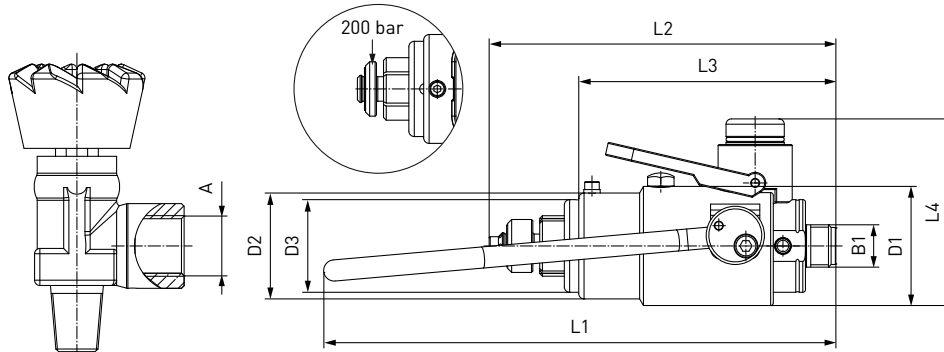

Part no.	Description	Pressure (PS)	A (female thread)	B1 (male thread)	L1	L2	L3	L4	D1	D2	D3
C1-92776-X01	CLICKMATE® TW154	250 bar	G5/8"	M16x1.5	194	122	97	70	45	40	35
C1-92777-X01	CLICKMATE® TW154	375 bar	G5/8"	M16x1.5	194	131	97	70	45	40	35

* acc. to DIN 477

ORDERING | Quick connector CLICKMATE® TW154 with operating loop no. 1 (suitable for Interspiro)

approx. dimensions (mm)

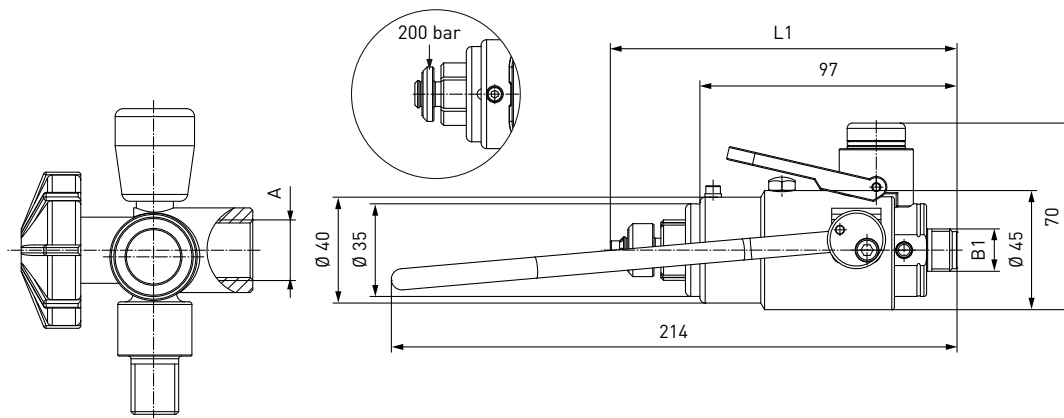

Part no.	Description	Pressure (PS)	A (female thread)	B1 (male thread)	L1	L2	L3	L4	D1	D2	D3
C1-109697-X01	CLICKMATE® TW154	250 bar	G5/8"	M16x1.5	214	122	97	70	45	40	35
C1-109698-X01	CLICKMATE® TW154	375 bar	G5/8"	M16x1.5	214	131	97	70	45	40	35

* acc. to DIN 477

» CLICKMATE® TW154 | Direct connection to hose filling systems

ACCESSORIES

The following accessories are available for the **CLICKMATE®** TW154:

1 Swivel joint TD1

The swivel joint TD1 prevents twisting of the hose and enables the axial aligning of the connector.



Part no.	Description	Pressure (PS)	Connection
W6599-X01	Swivel joint TD1	400 bar	M16x1.5 male thread
B200B-049-00	Seal set for TD1	-	-

2 Adaptors

Adaptor for connection to the filling hose resp. for connection of the filling hose with the filling rig.



Part no.	Description	Pressure (PS)	Connection
W50357	For connection to the filling hose	375 bar	M16x1.5 male thread o-ring with 60° inner cone
W32294	For connection filling hose / filling rig (for PN = 200 bar)	375 bar	G5/8" female thread <i>DIN 477 No. 13</i>
W33959	For connection filling hose / filling rig (for PN = 300 bar)	375 bar	G5/8" female thread <i>DIN 477 No. 16</i>

3 Filling hose



Part no.	Description	Pressure (PS)	Connection
E68-32040	Filling hose Hose length 1.5 m / Nominal bore DN 5 mm (incl. TÜV approval)	425 bar	M16x1.5 female thread

Other hose lengths on request

SPARE PARTS

Various parts are available as spares for the **CLICKMATE®** TW154.

Part no.	Description
E51-308S508	Spare front seal for CLICKMATE® TW154

» CLICKMATE® | Versions

Of course there are many other versions of our CLICKMATE® Quick connectors available, e.g. with operating lever, bleeding valve or check valve, for twin cylinder packs etc.

And WEH also offers quick connectors for other standards, for example the CGA standard.

That's only a small variety of special connectors. Please do not hesitate to contact us for other versions!

CLICKMATE® TW154 WITH BLEEDING VALVE FOR FEMALE THREADS



- Standard connection for G5/8" female thread (*DIN 477*)
- Inlet B1: UNF 7/16"-20 male thread (adaptor)
- Max. allowable operating pressure PS: 375 bar
- Lateral operating lever
- Integrated bleeding valve
- Integrated adaptor at inlet B1
- Other designs on request

CLICKMATE® TW154 WITH BLEEDING AND CHECK VALVE FOR FEMALE THREADS

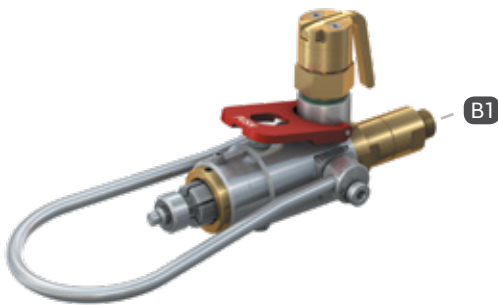

- Standard connection for G5/8" female thread (*DIN 477*)
- Inlet B1: M16x1.5 male thread (check valve)
- Max. allowable operating pressure PS: 375 bar
- Operating loop
- Integrated bleeding valve
- Integrated check valve at inlet B1
- Other designs on request

CLICKMATE® TW154 FOR FILLING TWIN CYLINDER PACKS



- Standard connection for G5/8" female thread (*DIN 477*)
- Inlet B1: G1/4" male thread with 60° inner cone (adaptor)
- Max. allowable operating pressure PS: 375 bar
- Lateral operating lever
- Integrated swivel joint TD1 at inlet B1
- Incl. adaptor
- Other designs on request

» WEH® Connector TW156 | For respiratory protective equipment

DESCRIPTION



Features

- Quick connection in seconds without hand tightening
- Robust design
- Easy connection means no straining of muscles, joints, etc.
- Improves operational safety and ergonomics

Respiratory protective equipment, such as SCBAs, must be regularly subjected to a functional test. WEH has developed the TW156 quick connector to automate this testing procedure. In seconds and without any laborious screwing the TW156 connects pressure-tight to the handwheel of the respiratory protective device. The clamping jaws grip onto the thread and the pressure-tight connection is made. It can either be connected directly to the existing test device or connected by a hose to the test device. When used with a hose, the connector must be secured when not in use.

All common test stations can be retrofitted without any problems.

The quick connector improves occupational safety and ergonomics and facilitates the testing of respiratory protective equipment.

The TW156 quick connector is available with manual or pneumatic actuation and has a red ring as a visual check to indicate if the quick connector is properly connected.

The WEH® TW156 is equipped with a NBR front seal. Other sealing materials are available on request. It is the customer's responsibility to clarify the media compatibility.

Application

Quick connector for testing respiratory protective equipment.

TECHNICAL DATA

Characteristics	Basic version	Options
Max. allowable operating pressure PS	375 bar	On request
Pilot pressure	6 - 12 bar compressed air	On request
Temperature range	+5 °C up to +70 °C	On request
Medium	Breathing air (compressed air)	On request
Connection A (respiratory protective equipment)	Standard connection for G5/8" male thread (DIN 477)	On request
Pilot pressure port P1	G1/8" female thread	On request
Actuation	H = manual actuation of the lever V = actuation via pneumatic / manual finger pressure valve	On request: P = pneumatic actuation for automated applications and activations
Material	Corrosion-resistant stainless steel Extensions: chromed / brass	On request
Sealing material	NBR	

Other designs on request

» WEH® Connector TW156 | For respiratory protective equipment

SYSTEM OVERVIEW

For the WEH® TW156 Quick connector various actuations and lateral extensions are available. The following schematic diagram shows an overview of these versions.

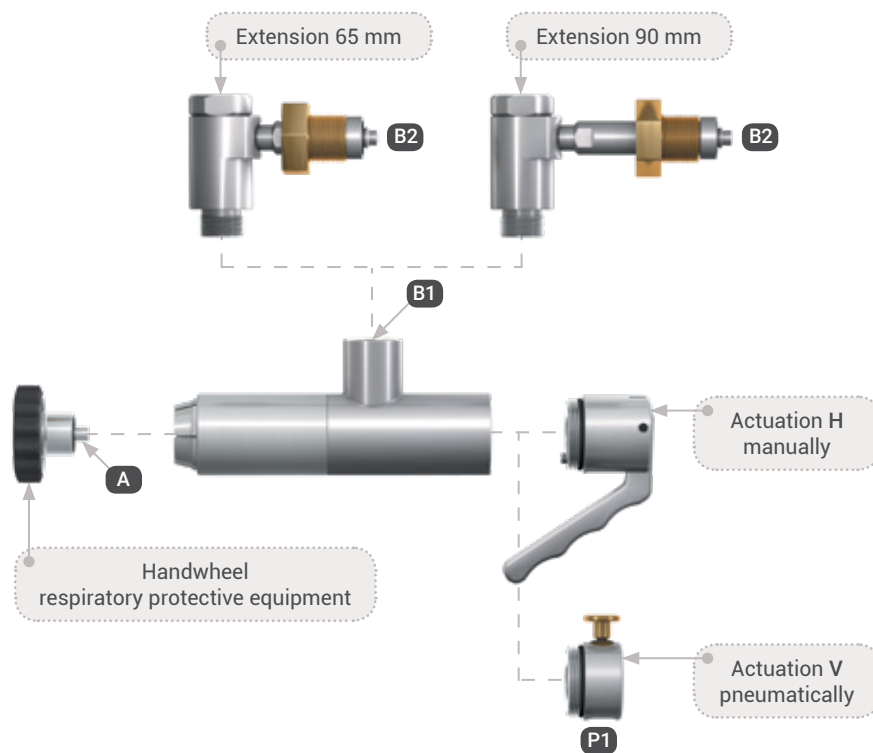

Port definition

- A** Connection respiratory protective equipment
- B1** Media inlet
- B2** Media inlet on versions with extension
- P1** Pilot pressure line (actuation V)

» WEH® Connector TW156 | For respiratory protective equipment

ORDERING | Quick connector TW156 with extension for SCBAs with carrying system

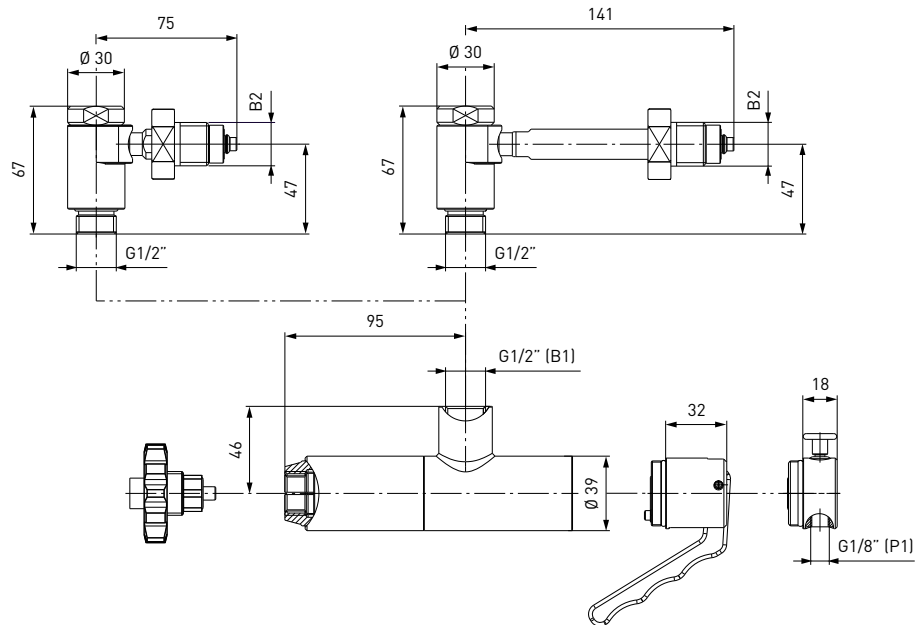

Part no.	Description	Pressure (PS)	Actuation	B2 (male thread)
C1-55640*	Elbow extension 90 mm	375 bar	Manually H	G5/8"
C1-35615**	Elbow extension 65 mm	375 bar	Manually H	G5/8"
C1-67670**	Elbow extension 65 mm	375 bar	Pneumatically V	G5/8"

* suitable for MSA (Multi-/Proficheck), Dräger (Quaestor 5000/7000)

** suitable for Dräger (Quaestor III/automatic), Labtec

Other versions (e.g. elbow extension 130 mm) on request.

» WEH[®] Connector TW156 | For respiratory protective equipment

» Technical appendix

Definitions

Abbreviation	Definition	
Pressure specifications		
PN	Nominal pressure	Nominal pressure after temperature compensation at 15 °C (59 °F)
PS	Max. allowable operating pressure	Maximum allowable operating pressure acc. to Pressure Equipment Directive 2014/68/EU, Article 2 paragraph 8
PT	Hydrostatic test pressure	Hydrostatic test pressure acc. to Pressure Equipment Directive 2014/68/EU, Annex I no. 7.4
PP	Pilot pressure	Actuation pressure for hydraulic and pneumatic components
PC	Cracking pressure	Pressure at which the check valve opens and the first indication of flow occurs
WP	Working pressure	'Working pressure' means the maximum pressure to which a component is designed to be subjected to and which is the basis for determining the strength of the component under consideration
MAWP	Max. allowable working pressure	Max. allowable operating pressure at which the weakest point of the system or the vessel (e.g. cylinder valve) can operate at a certain temperature during normal operation
Dimensions		
L1, L2, L3 ...	Length specification	
D1, D2, D3 ...	Diameter specification	
A/F(1), A/F(2) ...	Wrench size specification	
Ports		
A / X	Customer-specific port (test piece, sample, cylinder valve, handwheel respiratory protective equipment)	
B1, B2, B3 ...	Media ports	
C1, C2, C3 ...	Gas recirculation ports	
P1, P2, P3 ...	Pilot pressure ports	
MA1, MA2 ...	Measuring ports	
Q	Drain port filter	
G	Mounting bores	
Others		
DN	Nominal size (DN) acc. to Pressure Equipment Directive 2014/68/EU, Article 2 paragraph 11	
µm	Max. diameter of the filtered particle	
Kv	Is the discharge of water in m ³ /h at a pressure drop of 1 bar (14.5 psi), acc. to DIN/EN 60534-2	
Cv	Is the discharge of water in gallons per minute at a pressure drop of 1 psi, acc. to DIN/EN 60534-2	
IR	Infrared data interface	
ENR	Exchangeable data interface (exchangeable nozzle receiver)	
TS	Maximum allowable temperature acc. to Pressure Equipment Directive 2014/68/EU, Article 2 paragraph 9	

» Technical appendix

Definitions

Abbreviation	Definition
Breakaway force	Is the force range, in which the breakaway releases
NC	Normally closed (initial position of shut-off valve)
NO	Normally open (initial position of shut-off valve)

Technical explanations

Term	Definition
Temperature range	Is the temperature range in which the WEH® Product can be used.
Media temperature range	Is the temperature range of the medium used, which can flow through the WEH® Product (may change depending on the time of measurement).
Ambient temperature range	Is the temperature range of the environment in which the WEH® Product can be used.
Leak rate	Is the maximum external leak rate, which the WEH® Product exhibits in delivery condition.
Internal leak rate	The internal leak rate depends, among other things, on type of application, medium and pressure difference on the WEH® Product. On request it can be specified more precisely.
Max. side load	<p>Is the max. allowable sum of all external forces that may act on the device under intended use.</p> <p>Note: External forces can affect the life time of WEH® Products and can cause damage. Tensile and transverse loads as well as vibrations and pressure impacts need to be considered, e.g. by user side measures such as on site mountings and similar. Therefore, lateral forces such as whipping hoses or other equipment must be avoided. WEH® Products should be installed in such a way, that lateral forces which could lead to leakage or damage can not occur. Special applications require a special consultation before selecting the product.</p>
Products with pneumatic actuation	The customer has to ensure there is adequate axial movement when pneumatically actuated WEH® Products are used in automated systems, see maximum side load. Ideally the products should be mounted with a floating joint or introduced individually to prevent the possibly existing clamping jaws getting blocked or jammed in the thread of the test piece.
Sealing material	<p>On request the WEH® Product can be adapted to customer specific applications regarding to the sealing materials used.</p> <p>The clarification of the media compatibility and suitability of the adapted WEH® Product for the final application is always the responsibility of the end user.</p>
Storage / life time of components	<p>There are certain requirements for every WEH® Product.</p> <p>WEH® Products are generally products which may be subject to wear and fatigue during operation and depending on your individual application/use. For details - in particular regarding the corresponding minimum inspection and maintenance intervals – please refer to the respective operating instructions for the WEH® Product.</p>

» Technical appendix

Further explanations

Subject	Definition
Safe product selection	<p>Our WEH® Products are designed to be operated by qualified professional users (insofar as WEH® Products are also designed to be operated by other users in individual cases, this is explicitly stated in the corresponding operating instructions). Please note that WEH does not know your system and therefore - also due to the large number of different potential applications of WEH® Products - cannot perform tests on all potential types of application. You alone are responsible for the selection, configuration and suitability of WEH® Products, especially according to the requirements of your system. Before purchasing WEH® Products, please particularly ensure that our products are compatible with your intended use, your performance data, your material and fluids, your system concept and your system limits according to our product specifications. Please also consider your technical and legal requirements for operation, handling and maintenance. The quality and safety of WEH® Products is our highest priority. For this reason, WEH® Products may not be used outside the specifications in the relevant data sheets and product descriptions. If you are not sure whether the WEH® Product is suitable for your system and intended use, please contact us in advance. We also strongly recommend that you refrain from using third-party spare parts or a combination of WEH® Products with unsuitable third-party products. You alone are responsible for reviewing the suitability of third-party products. WEH® Products and WEH® Spare parts comply with our quality and safety standards.</p>
Explanation on the Pressure Equipment Directive	<p>In general, WEH® Products with a maximum allowable operating pressure of more than 0.5 bar (PS) fall within the scope of application of the Pressure Equipment Directive 2014/68/EU, are generally classified as pressure accessories in accordance with Article 2 (5) of the same and are considered to be similar to piping. These WEH® Products may not be used as safety accessories. Furthermore, it is pointed out, that these WEH® Products are designed and placed on the market in accordance with the requirements of Article 4 (3) of the Pressure Equipment Directive 2014/68/EU.</p> <p>For some products a different classification and/or categorisation is required or can be conducted on request. In these cases, if legally required, a conformity assessment procedure in accordance with Annex III of the Pressure Equipment Directive 2014/68/EU can and will also be conducted and the conformity can be declared by means of an EU Declaration of Conformity in accordance with Annex IV of the Pressure Equipment Directive 2014/68/EU. In these cases, the EU Declaration of Conformity is enclosed with the product.</p>
External change management	<p>WEH reserves the right to update, optimise and adjust its products continuously. This may result in corresponding changes of the product. Customers will be informed proactively or unsolicited by WEH only in individual cases about product updates, product optimisations and/or product adaptations that have been carried out. You are free to contact WEH at any time to request information about any product updates, product optimisations and/or product adjustments.</p>

» Brochure data

This catalog was created diligently and on the basis of decades of experience.

All information/recommendations in this catalog are non-binding and are particularly subject to possible deviations or changes. For any binding information/recommendations, please refer to the verified information/recommendations in our individual orders. Particularly, due to the wide range of possible applications of WEH® Products and the unknown parameters and operating conditions linked to them, the accuracy and/or completeness of the information/recommendations in this catalog cannot be guaranteed with respect to certain individual cases. In doing so, we would like to refer once again to the information/recommendations provided in individual orders.

The application limits indicated in this catalog (e.g. for pressure, temperature, etc.) are generally theoretical values determined in a test environment. As the concrete operating conditions could differ, we cannot ensure that these values apply to a specific customer application. During the practical use, you should particularly consider that the mutual influence of operational parameters could result in changes of the maximum values. Especially, in case of any unusual operating conditions, please contact WEH before using any WEH® Products. We therefore strongly recommend that you also require any necessary binding information/recommendations to be included by us in the individual orders.

Furthermore, we point out that we cannot assume any warranty or accept any responsibility for printing errors, incomplete information or misinterpretations. Illustrations and/or images are particularly provided for illustrative purposes only and may differ in some details from the actual product. Moreover, dimensions and other technical details in this catalog are non-binding information and are provided for illustrative purposes only. The product's exact form and design result exclusively from the specific individual order. In particular, certain information/recommendations in the catalog only become integral part of the contract if they have been expressly contractually agreed.

Only the latest version of our catalog and other product related documents is valid and applicable. Please ensure that you always use the latest catalog's and documents' versions. Please feel free to contact WEH at any time and request the latest versions.

In case of deliveries and other services, our General Terms and Conditions and the Know-How Protection and Quality Assurance Agreement shall apply unless otherwise expressly agreed.

As a general rule, please appreciate that we cannot accept the General Terms and Conditions of our customers or third parties. Thank you for your understanding.

Design and production

WEH GmbH Precision Connectors
Josef-Henle-Str. 1
89257 Illertissen / Germany

Phone: +49 7303 9609-0
E-Mail: sales@weh.com
Website: www.weh.com

More questions? – Great! Don't hesitate to contact our experts.