

TEESING

WWW.TEESING.COM

GSB SUBSEA SINGLE BOLT CONNECTORS



WWW.TEESING.COM | +31 70 413 07 50

Making The Right Connection

TEESING

WWW.TEESING.COM

GSB SUBSEA SINGLE BOLT CONNECTORS

The Destec GSB Subsea Single Bolt Connector is a purpose designed unit for operations where a conventional four bolt G-Range pipe connection would be impractical.

The GSB Connectors are supplied with a mounting plate which can if required accommodate guidance / pull-in systems for ease of alignment and provision for stab connectors for electrical and hydraulic circuits.

Standard G-Range or D-Range metal to metal Seal Rings can be used, or the customers own sealing arrangement can be employed.

Larger sizes and special designs (Dual Bore / Multi Bore / Concentric Bore) can also be accommodated. For example some GSB Connectors have been supplied with fabricated Spool pieces for mating to flexible risers.

For Subsea applications the GSB Connectors would be supplied with a combination of Molykote and Epoxy resin coatings. Designed for remote operations in the most demanding deep and ultra-deep water.



Alongside the standard clamp type connector there has always been a need for a connector where either repeated assembly, operation by remote operated vehicles, or powered drive has favoured the use of single bolt type connectors.

Destec Engineering now have many years of experience supplying these single bolt connectors in a very wide range of sizes, materials and pressure ratings. By using the range of Destec's conical seal rings, the units are compact and cost effective, and have significant advantages where weight is a problem.

- The Destec GSB Single Bolt Clampset is a purpose designed unit
- Supplied with a Mounting Plate and provision for Stab connectors for Electrical and Hydraulic circuits
- Guidance / Pull-in Systems ease of alignment
- Size Ranges from 2" - 60"
- Codes ASME VIII, API, BS
- Clamp mounting in any orientation. [Vertical & Horizontal]
- Design Life in Excess of 25 years
- Trouble - Free Remote Installation
- Compatible with ROV pull-in systems
- Dual bore, Multi bore & Concentric bores
- Fabricated Spool pieces for mating to Risers
- Pressure Ranges: 3000, 5000, 10000, 15000psi
- Seal replacement with ROV carried tools
- Seal Test arrangement included
- Soft Landing Cylinder function
- Fitted with standard API torque receptacles
- Lloyds design verification / appraisal available on all sizes
- Functional testing including pressure testing up to 22,500 psi
- FAT tested

WWW.TEESING.COM | +31 70 413 07 50



Most of the single bolt connectors have many customer's unique special requirements which we are able to incorporate in the designs. Some of the main features and details are listed below:

- **WEIGHT SAVING BY USING DESTEC METAL SEAL RINGS, SEALING AT A MINIMUM DIAMETER, AND ALSO USING HIGH STRENGTH HEAT-TREATED AND TEMPERED MATERIALS FOR THE CLAMPS.**
- **MATERIALS SELECTED ARE COATED SUITABLE FOR MOST ENVIRONMENTS INCLUDING SUBSEA.**
- **AS THESE CONNECTORS ARE OFTEN REMOTELY OPERATED, THE DESTEC SEAL RINGS CAN EITHER BE PERMANENTLY ATTACHED TO ONE HUB OR MAY BE REMOVABLE OR REPLACED BY A REMOTE OPERATED TOOL.**
- **DRIVE TO THE SINGLE BOLT CONNECTOR CAN BE MANUAL, OR USE AIR, HYDRAULIC OR ELECTRIC TIGHTENING DEVICES.**
- **DESTEC CAN PROVIDE SYSTEMS WITH ALL THE NECESSARY LIMIT AND SAFETY CONTROLS FOR OPERATION.**
- **SUBSEA CONNECTORS OPERATED BY REMOTE OPERATED VEHICLES ARE EQUIPPED WITH STANDARD API TORQUE RECEPTACLES AND GUIDES.**
- **SECONDARY SEALING TOGETHER WITH TAPPINGS FOR LEAKAGE MONITORING. ON SUBSEA APPLICATIONS THIS WOULD BE PROVIDED WITH A STAB CONNECTOR.**
- **MULTIPLE PIPE CONNECTORS WITHIN ONE LARGE SINGLE BOLT CLAMP.**

Applications include large pressure vessel closures down to pipe connectors used for subsea hook-up. Some of the variety of applications have been shown in detail on pages 06 and 07.



“Destec Connectors - Field proven around the world. An extensive track record subsea with many years of service”

WWW.TEESING.COM | +31 70 413 07 50

CONNECTOR MATERIALS

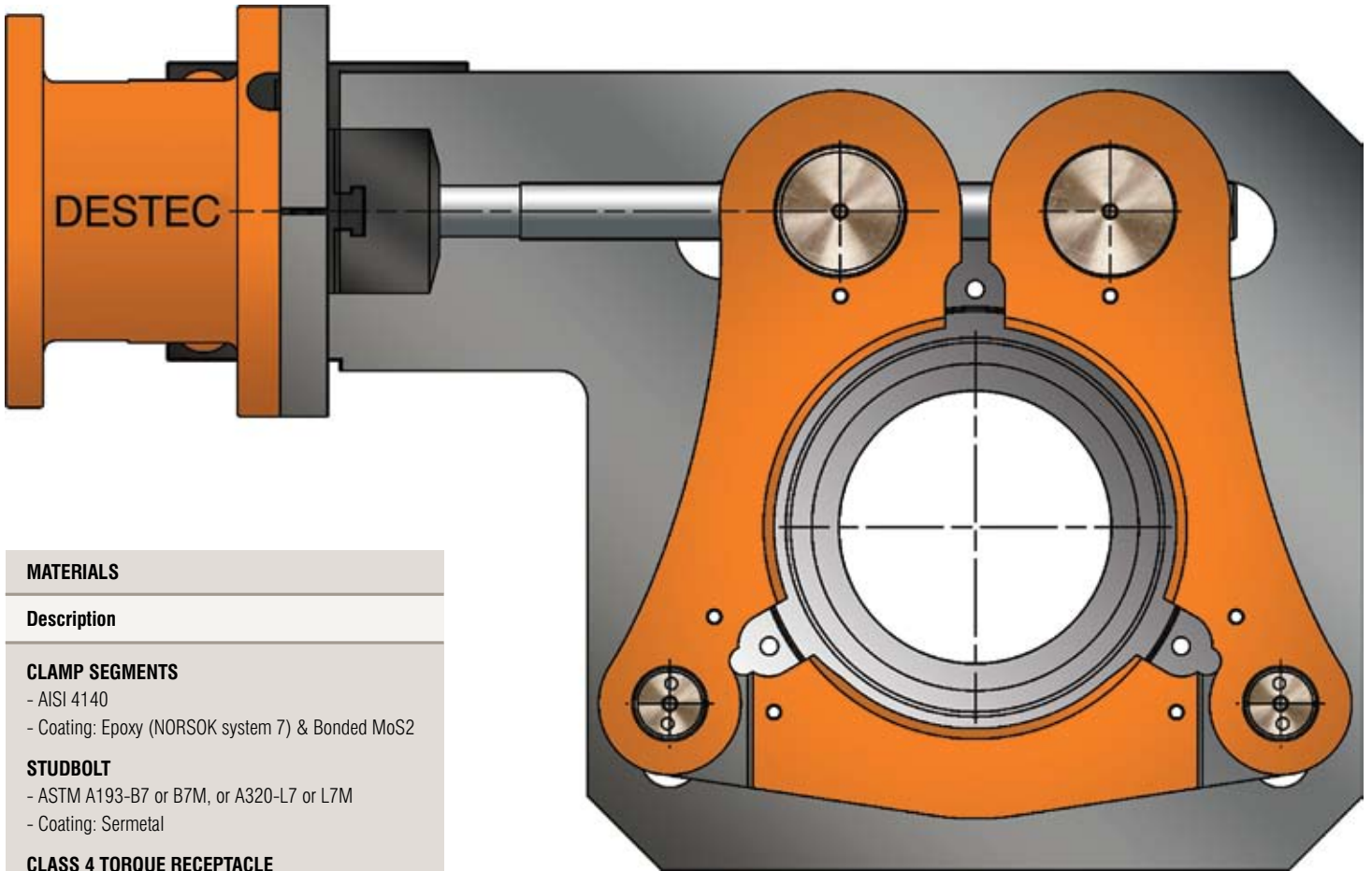

MATERIALS
Description
CLAMP SEGMENTS
- AISI 4140
- Coating: Epoxy (NORSOK system 7) & Bonded MoS2
STUDBOLT
- ASTM A193-B7 or B7M, or A320-L7 or L7M
- Coating: Sermetal
CLASS 4 TORQUE RECEPTACLE
- Cast Steel A216 WCB
SEAL RINGS
- Inconel 718 & X750 , PTFE
MOUNTING PLATE
- S355J2
- Coating: Bonded MoS2
BELLOWS (not shown see page 2)
- Polyurethane-Grease Filled
TRUNNION NUTS
- NES 833 Gr.1 (Nickel Bronze)
HINGE PINS
- ASTM A320-L7M
- Coating: Bonded MoS2 Epoxy

**BW Hubs - A694 F65, 3mm Inconel 625 overlay
22% Cr Duplex and 25% Cr Super Duplex**

For Subsea Applications the GSB Connectors are supplied with a combination of Molykote and Epoxy resin coatings.

All materials listed above are Destec standard, however other material grades can be specified as per customers requirements.

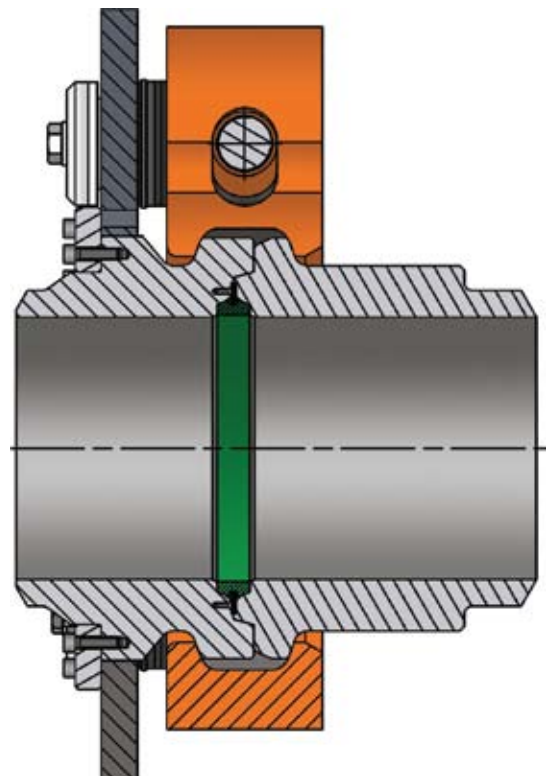

WWW.TEESING.COM | +31 70 413 07 50



DIMENSIONS & WEIGHTS

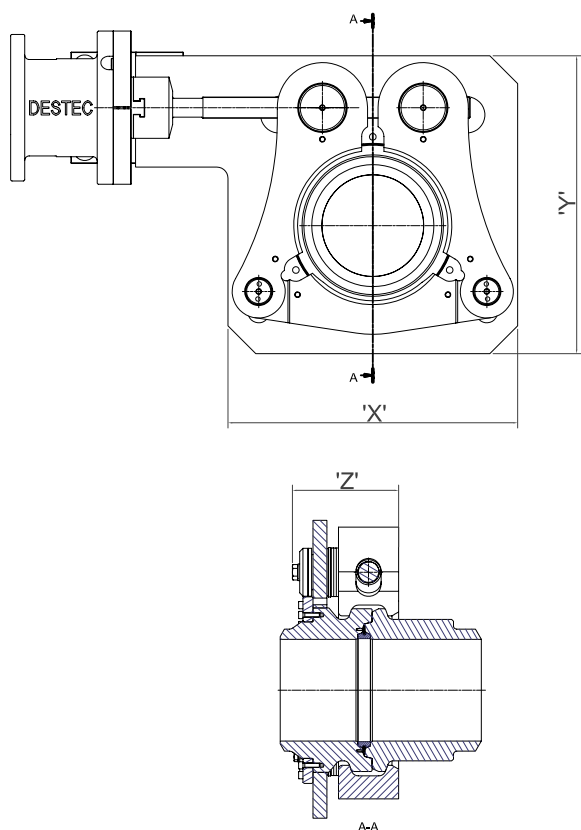

Sizes are based on API 6A and AISI 4130 (60k) hub material

SIZE	RATING psi	Max Bore	Space Envelope			Mass (excludes hubs & seal)	
			X in (mm)	Y in (mm)	Z in (mm)	lb	kg
G2SB	15000	1 13/16	9.843	9.094	4.606	123	55.7
	10000	2 1/16	(250)	(231)	(117)		
	5000	2 1/16					
G3SB	15000	2 1/16	12.205	11.024	5.512	152	68.7
	10000	2 9/16	(310)	(280)	(140)		
	5000	3 1/16					
G4SB	15000	2 9/16	13.386	13.386	6.220	196	89
	10000	3 1/16	(340)	(340)	(158)		
	5000	4 1/16					
G5SB	15000	3 1/16	15.748	14.961	6.575	212	96
	10000	4 1/16	(400)	(380)	(167)		
	5000	5 1/8					
G6SB	15000	4 1/16	19.685	18.898	7.283	344	156
	10000	5 1/8	(500)	(480)	(185)		
	5000	6 1/16					
G8SB	15000	5 1/8	20.472	21.063	7.520	432	196
	10000	6 1/16	(520)	(535)	(191)		
	5000	7 1/16					
G10SB	15000	6 1/16	27.559	25.039	8.819	600	272
	10000	7 1/16	(700)	(636)	(224)		
	5000	9					
G12SB	15000	7 1/16	30.709	28.937	10.039	977	443
	10000	9	(780)	(735)	(255)		
	5000	10 13/16					
G14SB	15000	9	33.465	32.677	10.039	1171	531
	10000	11	(850)	(830)	(255)		
	5000	12 5/8					
G16SB	15000	11	33.228	33.346	10.394	1080	490
	10000	12 5/8	(844)	(847)	(264)		
	5000	13 5/8					
G18SB	15000	12 5/8	39.370	38.586	11.457	1587	720
	10000	13 5/8	(1000)	(980)	(291)		
	5000	15 3/4					
G20SB	15000	13 5/8	43.701	42.913	12.402	2194	995
	10000	15 3/4	(1110)	(1090)	(315)		
	5000	16 3/4					

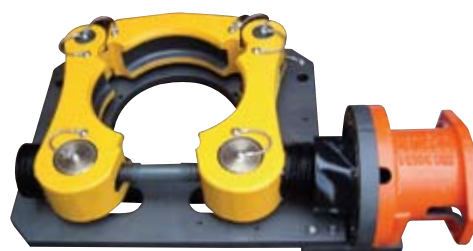
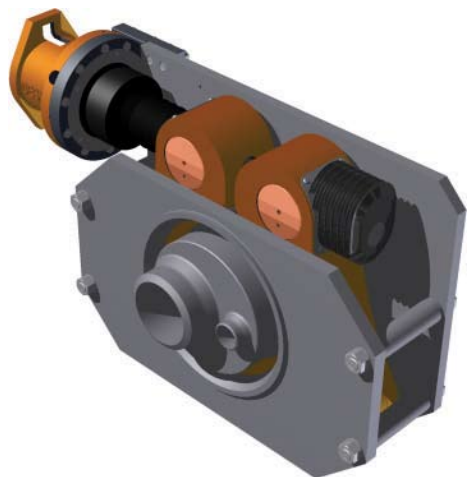

WWW.TEESING.COM | +31 70 413 07 50

SUBSEA APPLICATIONS

Single Bolt Clamps for Choke Retrieval Subsea.

Destec Single Bolt Clamps are in service in the following fields:

- BP FOINAVEN
- BP SCHIEHALLION
- BP SWIFT
- BP CIRRUS
- NORSE HYDRO TROLL
- EXXON MOBIL EPS / KIZOMBA
- BRITISH GAS BLAKE
- BURULLUS GAS SCARAB/SAFFRON
- AMOCO KING
- WOODSIDE ECHO YODEL
- ENTERPRISE COOK / PIERCE
- SHELL MALAMPAYA

Over 1000 Destec Single Bolt Clamps are in use on Retrievable Subsea Chokes. The clamp is an integral part of the bonnet cover and is retrievable to the surface together with the valve trim.

The bolt is fitted with API torque receptacles, to match the particular field standard, for ROV use. Bearings on the bolt ensure smooth even make-up and break.

The clamp mounting plate illustrated is precision bored for additional hydraulic stab connectors and guide pins.

This 10" nominal clamp has API ratings of:

- 15,000 lb/sq.in. at 6" (150mm) diameter**
- 10,000 lb/sq.in. at 7" (180mm) diameter**
- 7,500 lb/sq.in. at 8" (205mm) diameter**
- 5,000 lb/sq.in. at 9" (230mm) diameter**

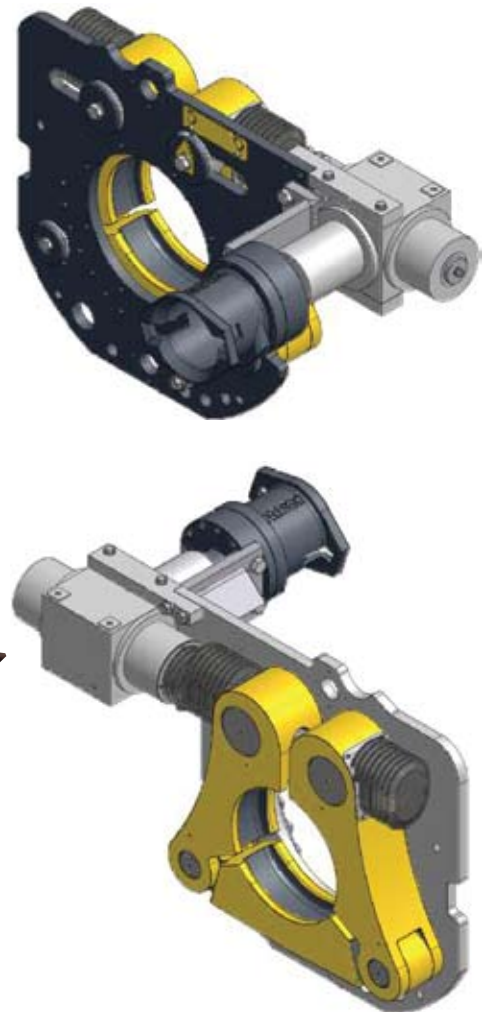

Destec Connector Chosen for First 15,000 psi ROV Hook-up

Destec Engineers worked closely with the Engineers at Sonsub in Houston to perfect the worlds first 15000 psi ROV Hook-up.

The successful installation is on the Gyrfalcon Field, Block 20 in the Gulf of Mexico. The 8" Connectors were supplied complete with a guidance system preventing damage to the hub ends which are also designed to protect and retain the Destec seal ring.

Secondary sealing enables monitoring by the ROV of the connector performance whilst externally preventing the ingress of sea and sand.

The adjacent photograph shows hook-up simulation tests being carried out in the fabricators yard.

The main guidance system also incorporates soft land equipment which can be activated to assist initial pipeline separation.





SUBSEA APPLICATIONS

3 Piece Single bolt Subsea Clamps for the Seal Tube Air locks on the Troll Production Platform

A total of seven 32" (813 mm) and 49" (1245 mm) diameter Single Bolt Clamps are installed at the base of the Troll Platform Leg at a depth of 1000 ft (325 m). The units form part of Seal Tube Air Locks and are used for current and future Hook Ups to production wells.

Operation of the Destec Clamp is by ROV and when required a safety link is removed before opening the Single bolt Clamp. The cover together with the stopple equipment cartridge is then removed and brought to the surface.

Design pressure is 508psi (35 bars), with two of Destec's unique conical seals used for internal and external pressurisation. This system allows for monitoring the sealing integrity.

On the right, the seven Destec closures are in the final position for construction of the concrete support leg of the Troll platform in Norway.

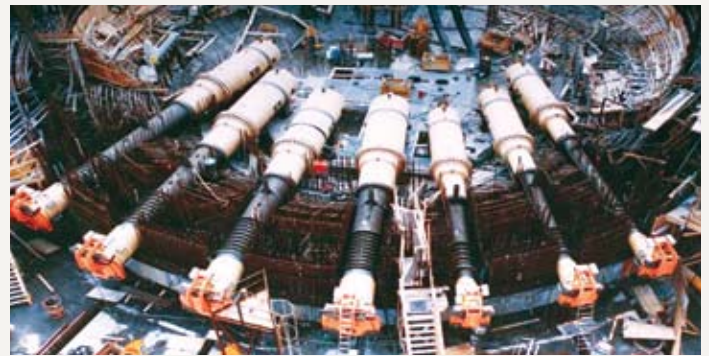

8" Single Bolt Clamps for Kerr McGee Janice Field

On the Kerr McGee Janice Field eleven 8 inch Destec Spool assemblies are used to connect the flowlines to the wellheads.

The units supplied comprise a G8SB Destec hub to 51/8 API 10K 36° fabricated spool clad with Inconel 625, a G8SB Inconel line blind and a Destec single bolt clampset. They form part of the wellhead assembly and are pressure tested to 15000 lb/in² (1034 bars), and comply with API 6A 75K, PSL3 material class HH, temperature class X and NACE MR 01-75.

In service the blind is removed and the flexible flowline connected by ROV.



Single Bolt Clamps for the South Arne Gravity Based Structure

Destec's Single Bolt Connectors are used in three separate applications on the South Arne GBS.

The photograph to the right is a 36" (915 mm) bore roof access hatch on the buffer cell.

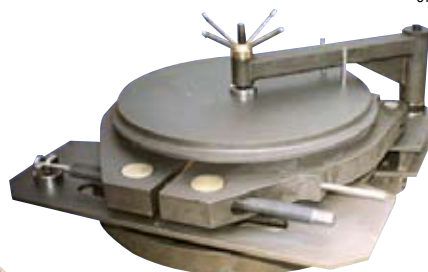

The hatch is submerged and diver operated. Contained fluid is either product or sea water. Two 24" (600 mm) Destec Single Bolt hatches together with debris guards are installed on the cells of the GSB and fitted with torque receptacles for ROV operation.

Four 18" (457 mm) seawater hatches shown below are fitted with 8" valves. Both the Destec Single Bolt Clamp and the valve are ROV operated. These seawater port closures are fitted to the GBS tower.



WWW.TEESING.COM | +31 70 413 07 50

MISALIGNMENT CAPABILITY

Alignment capability is dictated to some degree by the method of deployment and the supporting structure.

We utilise guide cones to accommodate initial offsets of up to 50mm and 5 degrees, however all connectors of this type need the hub faces to be positioned such that the clamp segments will engage the hub shoulders for tightening of the main studbolt to make up the connection.

- Male-Female configuration controls mis-alignment
- Radial mis-alignment varies with hub size
- Coarse mis-alignment provided by pull-in system
- Fine mis-alignment provided by male/female spigot system
- Radial profile to male spigot avoids snagging
- Guide Bars provide precise entry
- Angular & radial mis-alignment controlled to stop any damage to sealing surfaces during make-up

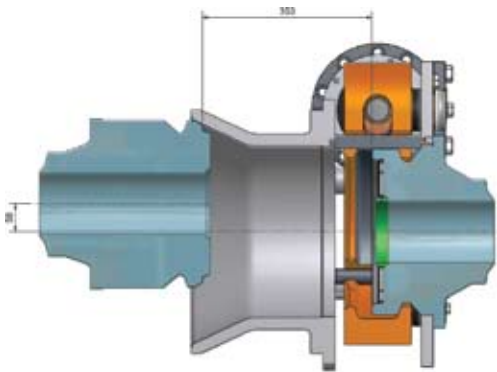

1. Guide Cone Provides 1st Take up of Misalignment

Male hub shown at 58mm radial offset. First contact occurs when 30° lead in on male hub shoulder touches the guide cone.

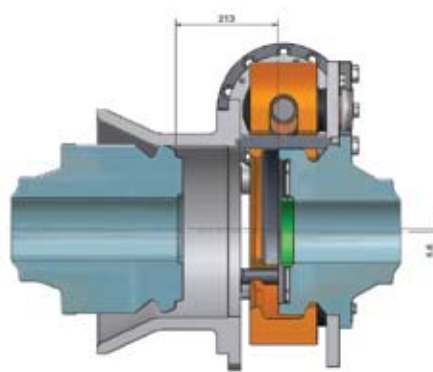

2. Guide Cone 'Funnels' Male Hub on Approach

Male hub shown at 5.6mm radial offset. Hub o/dia. channeled down bore of cone.

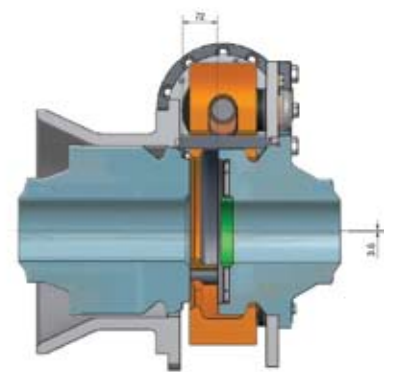

3. Step in Bore of Cone Further Reduces Misalignment

Male hub shown at 3.6mm radial offset.

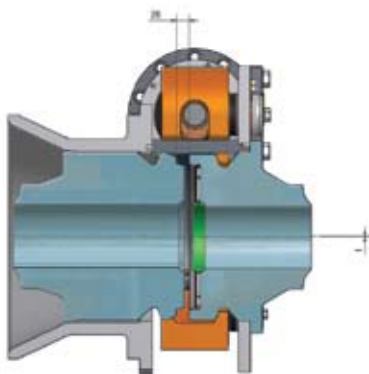

4. Guide Bars Provide More Precise Entry Into Clamp

Male hub shown at 1mm radial offset.

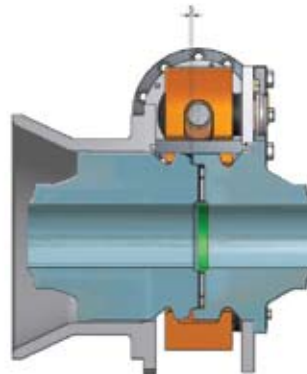

5. Male Spigot Provides Final Alignment

Connection shown with maximum gap at hub faces prior to bolt tightening. Constriction in cone bore and raised lip around hub o/dia. ensure hubs are square as well as concentric when the connection is to be made up.

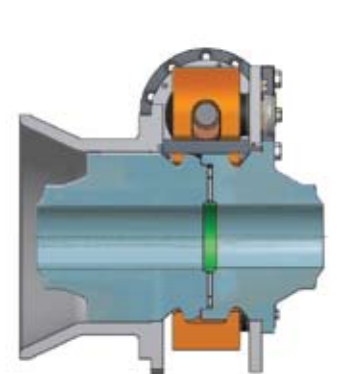

6. Fully Assembled Connection

Above alignment sequence refers to G10SB only. Other sizes available on request.
WWW.TEESING.COM | +31 70 413 07 50



SOFT LANDING SYSTEMS

A soft landing system for retrieval and installation is provided to minimize impact loads.

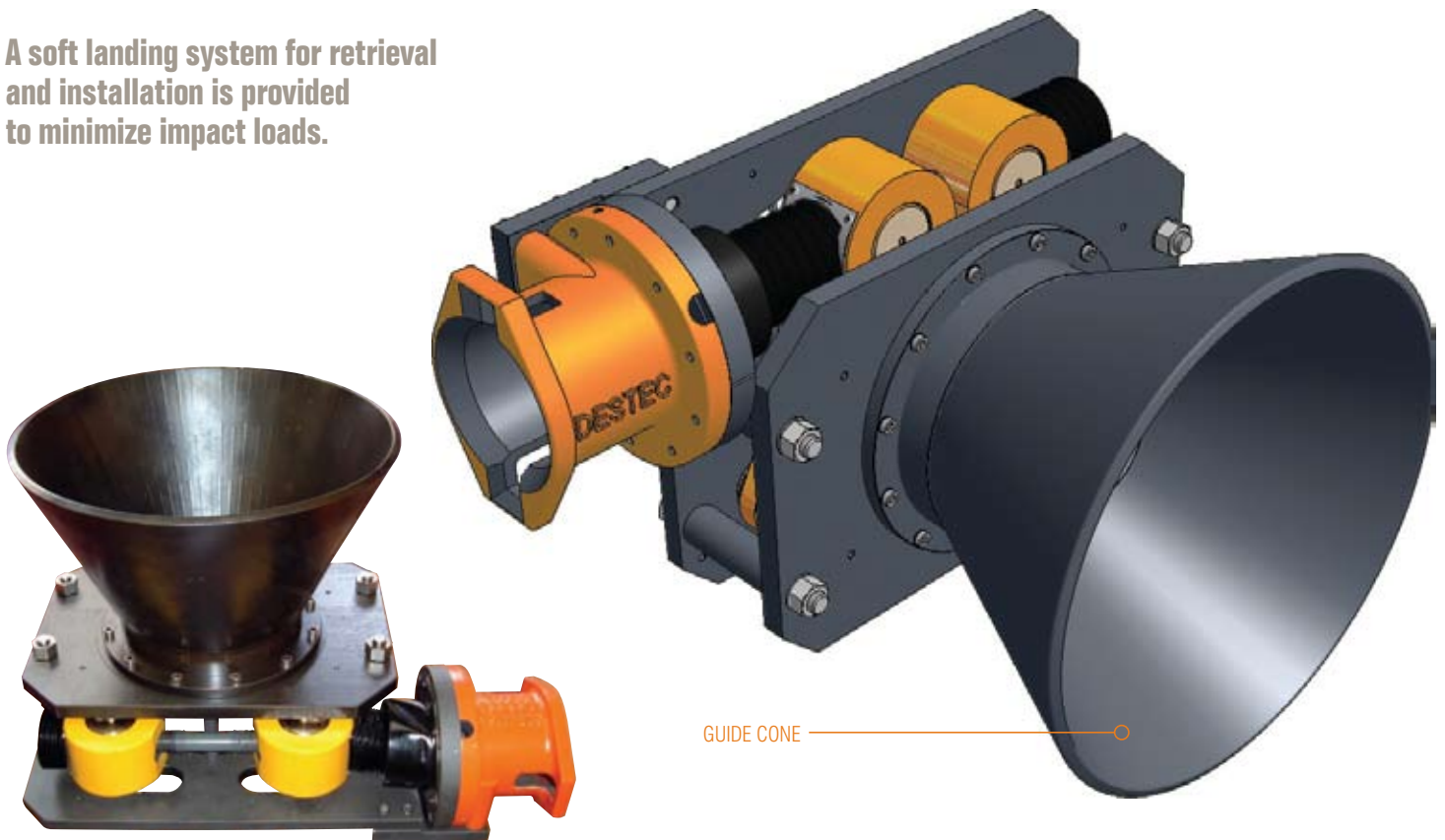

GUIDE CONE



- Be integral part of the connector or running tool
- Designed to absorb impact loads while landing onto the hub
- Maintain separation between sealing surfaces
- Support the weight of the jumper (isolate from vessel motion)
- Lower or raise the connector from the hub in a controlled manner
- Have mechanical indicators readable by ROV
- Allow each end of the jumper to be lowered or raised independently of each other

INSULATION SYSTEMS

Connector Insulation System - Doghouse Closure.

Bespoke Insulation Systems available for deep and ultra deepwater field developments. The thermal insulation of subsea connectors is essential to overcome flow assurance issues in order to maintain flow rates, reduce production costs and provide defence against wax and hydrate formations.

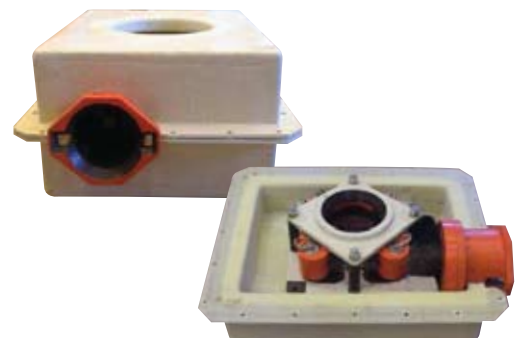

WWW.TEESING.COM | +31 70 413 07 50

Ⓢ ADDITIONAL FEATURES

BENEFITS OF DESTEC GSB SUBSEA CONNECTORS

- Engineered for remote operation in deep water
- Provides first time connection
- Greater operational efficiency
- Utilises Destec Metal Seal Ring Technology
- Adapted into customers own specification
- Quick connect & disconnect
- Compatible with ROV and sled pull-in systems
- Minimises mass and space envelope
- Design life in excess of 25 years



Other features and optional extras include:

- Destec Seal Ring is a multi - use design when specified in high strength materials. [Inconel 718 or X750]
- Seal Ring completely flush with the bore
- Bellows to protect Stud bolt from marine growth
- Tappings provided for mounting Anodes
- Cathodic protection
- Electrical continuity straps fitted as standard
- Hubs have tongue & groove features to assure alignment before seal ring contact
- Joint make-up is on a basis of torque value and target number of turns. [Open/Close indicator]
- Supplied over 1500 subsea clamp connectors
- Designed for depths in excess of 3,000m

Pressure Cap / Pull Blind



Pipeline End Module



Pig Launcher / Receiver Systems

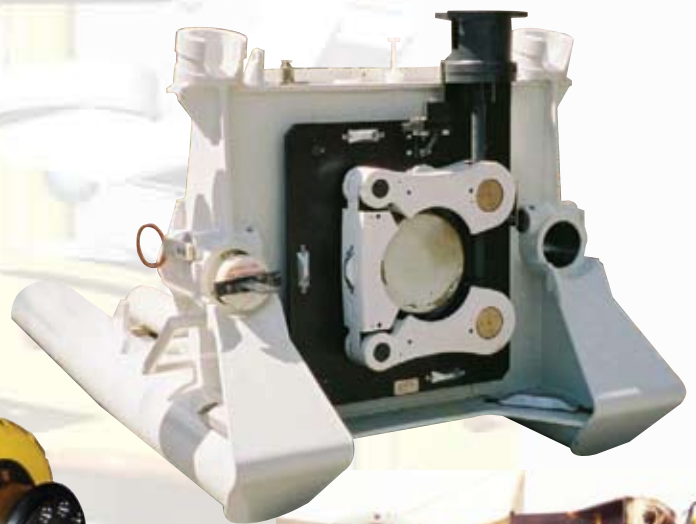

Hub Face Cleaning Tool

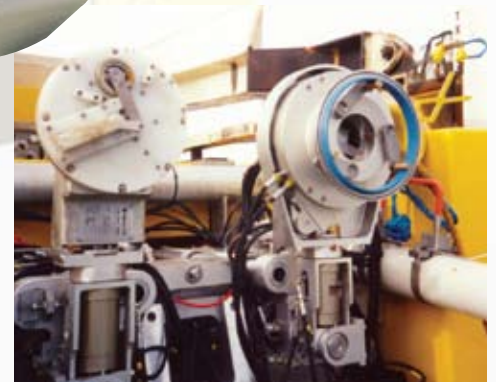

Seal Replacement Tool

WWW.TEESING.COM | +31 70 413 07 50



USER LIST

Project examples of typical connection applications:

CONTRACTOR	SIZE	PROJECT	APPLICATIONS	DEPTH
ABB Offshore Systems AS	5", 6"	ENTERPRISE	Structural Connection at 140 Km Bending, Kicker Line Connection	355m
ABB Offshore Systems AS	4"	SHELL	Subsea Riser Gas Lift System	1200m
ABB Offshore Systems AS	8", 10", 12"	STATOIL	Multibore Connection for Umbilical (ICARUS) & Choke Module	350m
Cameron Ireland Limited	10"	SUPPLIED OVER 1,000 TO MANY PROJECTS	7.1/16" 10K & 15K Subsea Choke Valves	Down to 2,000m
Cooper Cameron (UK) Limited	8"	KERR MCGEE	5.1/8" 10K Subsea Riser / Tree Connection	80m
Cooper Cameron (UK) Limited	16"	BP	Twin Bore Tree Connection	1200m
DES Operations Ltd	2", 6", 8"	BP, TOTAL, SHELL, CHEVRON	MARS-Multiple Application Re-injection System	2000m
EAB Engineering Solutions AS	4", 8", 10", 12", 18", 24"	NORSK HYDRO, SHELL, BP	Gas Injection Flowline, Flexible / Rigid Line Connectors	340m
EMH Limited	20"	MOBIL	Flexible Pipe on Riser to Seabed Anchorage	112m
Estech Europe Ltd	36"	DEMONSTRATOR	Vessel Closure for Recycling Municipal Waste	On Shore
Framo Engineering AS	4", 8", 14"	BHP, BG, SANTOS, PETROBRAS	Subsea Multiphase Flow Meters & Pumps	Down to 2,500m
3 Phase Measurements AS	6", 10"	BP, ATP, TOTAL, SHELL, BHP	Subsea Multiphase Flow Meters & Pumps	400m
Frank Mohn Flatoy AS	2", 6", 8", 10"	MARATHON, CNR, SHELL, TOTAL, WOODSIDE	Subsea Multiphase Pumps	Down to 2,500m
Haliburton Brown & Root	12"	STATOIL	Pig Launcher / Receiver	Topside
JP Kenny Inc	8"	CALLON ENTRADA	In-Field Flowlines	1,500m
Kvaerner Oilfield Products Ltd	10"	PETRO CANADA	Subsea Multiphase Flowmeter (2 x 4" Bore)	130m
MOFFAT 2000	3"	EXXON MOBIL	Pipe Spool Connections - Riser Cabinet	1100m
Oceaneering Inc	14"	SHELL	Subsea Pig Launcher	1030m
OMV (Australia)	6"	OMV / SANTOS	Wellhead to Pipeline Connection	55m
Sonsub International Inc	8"	SHELL	5.1/8" 15K Subsea Riser / Tree Connection	289m
Statoil	4"	STATOIL	Automated Closure for Gas Weigh Vessel	Topside
Taylor Woodrow M & E Ltd	18", 24", 36"	AMERADA HESS	Subsea Access Hatch	60m
Technip AS	8", 10", 12"	BP / ESSO	Flexible / Rigid Line / Subsea Pigging Structure Connectors	128m
Technip UK Ltd	4"	BURULLUS GAS	Jumper Connection System	500m
Technomarine	31", 49"	SHELL	Subsea Seal Tube Closures	303m
UHDE GmbH	60"	HENKEL	Closure- Multi Tube Hydrogenation Vessel	Topside
Wilson Systems	79"	Re3	Door Closures - Recycling Vessels	On Shore

Contact Destec for full user list.

DOOR CLOSURES

Destec door closures provide quick access to pressure vessels and can be operated safely at speed.

Applications include Industrial Waste Treatment closures, Pig traps, Separator vessels, Subsea Access Hatches and Medical Waste treatment vessels. Sizes ranging from 0.5m to 2m diameter. Please consult Destec Engineering Ltd for sizes outside this range.

Designed to meet ASME and other pressure vessel requirements for quick release connectors.

Destec Engineering offer front end design studies to determine cost effective solutions and provide manufacture and project management with our own in-house technical expertise.

A range of doors has been developed for domestic waste treatment plants designed for continuous and remote operation.

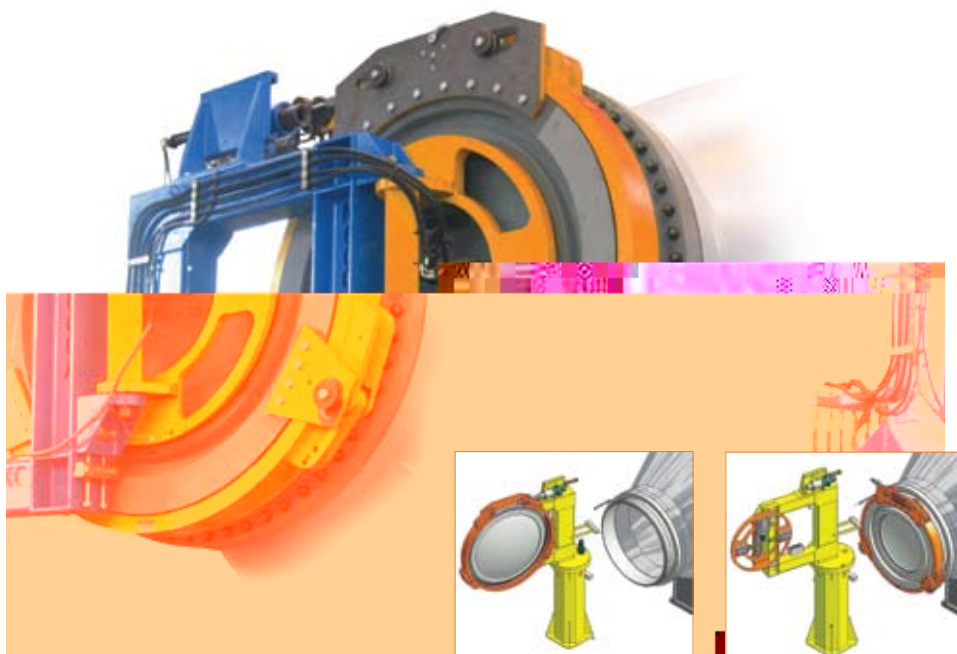

WWW.TEESING.COM | +31 70 413 07 50



Connector Applications.

Connector Applications include:

- RISER / TREE CONNECTIONS
- SUBSEA CHOKE VALVES
- MULTIPHASE FLOW METERS
- FLEXIBLE FLOWLINES & UMBILICALS
- RIGID JUMPERS & TIE-IN SPOOLS
- PIG LAUNCHER SYSTEMS
- WELLHEAD PIPELINE CONNECTIONS
- SUBSEA TIE-IN CONNECTION SYSTEMS
- HORIZONTAL & VERTICAL CONFIGURATION
- SINGLEBORE & MULTIBORE HUBS

Ordering Procedure.

If standard pipe is being used select connection size from integrated specification table.

Check pressure/temperature ratings for the materials required from tables.

Destec Engineering manufacture an extensive range of connections and should sizing be required, please supply the following information:

- DESIGN PRESSURE AND TEMPERATURE
- EXTERNAL PIPE FORCES
- PIPE MATERIALS AND CONTAINED FLUID
- PIPE OR PRESSURE VESSEL CODE
- PIPE BORE AND OUTSIDE DIAMETER
- QUANTITY INVOLVED
- ANY OTHER INFORMATION CONSIDERED RELEVANT TO DESIGN eg. CORROSION ALLOWANCE

Our Design Service.

DESTEC ENGINEERING offers the backing of a full team of engineers equipped with Finite Element Analysis and specialised in-house generated computer programmes. Including:

- FEA TO RELEVANT CODES
- 3D CAD (INVENTOR SUITE & PROFESSIONAL)
- 3D MODELS UPLOADED TO CLIENTS
- PROTOTYPE DEVELOPMENT & TESTING

Call us on: **+44 (0)1522 791 721** or email us at:
sales@destec.co.uk



WWW.TEESING.COM | +31 70 413 07 50

Destec Engineering Ltd
Five Mile Lane, Washingborough,
Lincoln, LN4 1AF. UK

TEL: +44 (0)1522 791 721

FAX: +44 (0)1522 790 033

EMAIL: sales@destec.co.uk

