

STAINLESS STEEL TWO-PIECE, FULL PORT ACTUATED BALL VALVES

BV2 - 2FA - 1/2" - 3" BSP/NPT

FEATURES

- Full port
- Investment casting body & cap
- Blow-out Proof Stem
- Full sizes range 1/2" - 3"
- ISO 5211 direct mount pad

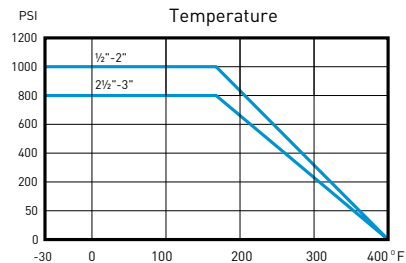
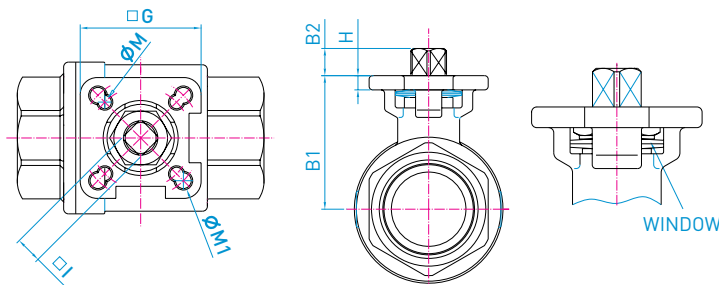

MATERIAL LIST

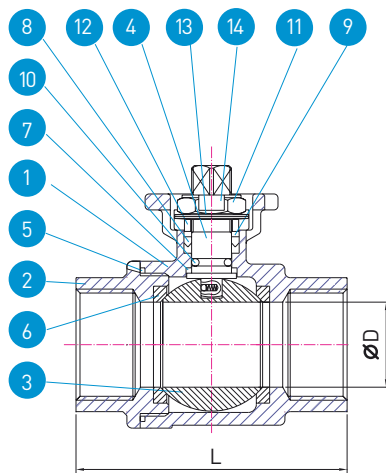

NO.	PART NAME	MATERIAL	Q'TY
1	Body	CF8M/1.4408	1
2	End cap	CF8M/1.4408	1
3	Ball	316SS	1
4	Stem	316SS	1
5	Body seal	PTFE	1
6	Seat	TFM1600	2
7	Stem seal	R.PTFE	1
8	V-ring packing	PTFE	1 SET
9	Bushing	50% S.S. Powder filled PTFE	1
10	O-ring	VITON	1
11	Stem nut	304SS	1
12	Gland	304SS	1
13	Belleville washer	301SS	2
14	Lock saddle	304SS	1

DIMENSIONS (MM)

SIZE	B1	B2	ØD	G	H	L	□	ØM	ØM1	ISO5211
1/2"	35.6	9.0	15	42	5.0	65	9	5.5	5.5	F03/F04
3/4"	38.8	9.0	20	42	5.0	75	9	5.5	5.5	F03/F04
1"	52.0	10.7	25	50	6.0	88	11	5.5	6.5	F04/F05
1 1/4"	56.8	10.7	32	50	6.0	100	11	5.5	6.5	F04/F05
1 1/2"	65.7	15.5	38	70	7.0	110	14	6.5	8.5	F05/F07
2"	73.9	15.5	50	70	7.0	123	14	6.5	8.5	F05/F07
2 1/2"	93.0	16.5	65	100	10.5	160	17	9.0	11.0	F07/F10
3"	102.0	16.5	80	100	10.5	175	17	9.0	11.0	F07/F10